



**U.S. Consumer Product Safety Commission
Virginia Graeme Baker Pool and Spa Safety Act
Verification of Compliance Form**

COMPLETE A FORM FOR EACH PUMP AT A FACILITY

PART I – Pool Management Information

OMB Control Number: 3041-0142

Investigator Name		Date of Inspection	
Facility Name		Pool License/Permit Number	
Address	Phone Number ()		
City	State	Zip Code	
Contact Name	Title		
Contact Address			
City	State	Zip Code	
Email Address	Fax #		

PART II – POOL/SPA Information

Pool Location	Indoor <input type="checkbox"/>	Outdoor <input type="checkbox"/>	Water Park <input type="checkbox"/>	Other <input type="checkbox"/>
Pool Type	Swimming Pool <input type="checkbox"/>	Wading Pool <input type="checkbox"/>	Spa <input type="checkbox"/> Hot tub <input type="checkbox"/>	Other <input type="checkbox"/>
Water Features (if any)	Spray <input type="checkbox"/>	Slide <input type="checkbox"/>	Hydro-jet <input type="checkbox"/>	Other <input type="checkbox"/>
Volume of Pool (Gallons)	Mfr, Make, Model Number, Horse Power of Pump			

Part III – Drain Covers

Total Number of Drain Covers in Pool/Spa <input type="checkbox"/>		Total Number of Drain Covers Installed for VGBA Compliance <input type="checkbox"/>				
Name of Manufacturer of Drain Covers _____		Drain Cover Expiration Date (s) _____				
Drain Cover	Drain Cover Dimensions & Shape (Round, Rectangular, Square, etc.)	Drain Cover & Frame Make and Model Number	Date Installed & Location (Wall or Floor)	Cover Flow Rate per Manufacturer Specifications (gallons per minute)	Pump Flow Rate (gallons per minute)	Cover Conforms to ASME/ANSI A112.19.8-2007 or newer standard (Indicate Yes/No)
1.						
2.						
3.						
4.						
5.						
6.						
7.						
8.						
9.						

10.					
<p>Note: Attach documentation that the drain covers comply with ASME A112.19.8 or successor performance standard ANSI/APSP-16 (effective Sept. 6, 2011). (i.e. Professional Engineer inspection report)</p>					

Part IV Anti-Entrapment Device/System

1. Single Main Drain Yes No
 Is this an unblockable drain that is larger than 18 x 23? Yes No (If no, go to next section)

2. Multi-Drain System Yes No
 Is the multi-drain system at least three (3) feet from pipe center to pipe center? Yes
 (See Attachment I, page 4) (If no, go to next section)

Select Secondary Backup System that is installed

Compliant Safety Vacuum Release System (SVRS) (Compliant with ASME/ANSI A112.19.17 or ASTM-F2387)
 SVRS Mfr. Name and Model _____

Suction-Limiting Vent System
 Mfr. Name and Model Number _____

Gravity Drainage System _____

Automatic Pump Shutoff System _____
 Mfr. Name and Model Number _____

Drain Disablement
 Describe how this was accomplished? _____

Other _____

Comments _____

Part V Sump – Equalizer Lines

Sump Size
 Width _____ Depth _____ Length _____

Is Sump existing or new _____ Is it field fabricated or manufactured _____
 Describe how it is fabricated? _____
 (If field fabricated, attach copy of certification from Professional Engineer)

Manufacturer Name and Model Number _____ Installation Date _____

Clearance between the bottom of the cover and the opening of the suction pipe is _____ (inches)

Equalizer Lines:
 Are equalizer lines disabled? (Yes/No) (If so, describe how) _____
 Do equalizer lines have covers that cannot be removed? (Yes/No)

Describe how this was accomplished _____

Provide manufacturer name AND model number for each equalizer cover _____

Installation Date _____

Part VI Comments

If pool is not in full compliance , provide a description of actions or steps needed to bring pool or spa into compliance with the Virginia Graeme Baker Pool and Spa Safety Act or attach timeline provided by the pool manager or documentation that drain covers have been ordered.

Comments

CPSC Investigator - Print Name

Signature

Date

CPSC Form 120 (07/10)

Note: This form must be completed by CPSC staff or the designated State or local government official.

CORRECT

3 FEET APART OR MORE

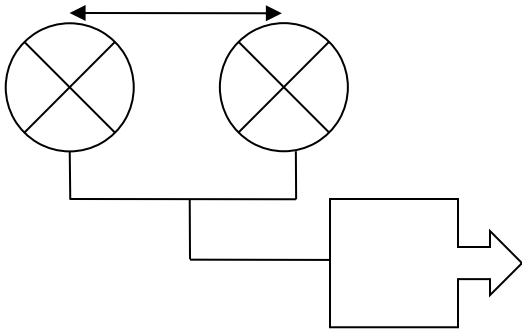

Dual Drain Outlets

CORRECT

3 FEET APART OUTMOST OUTLETS

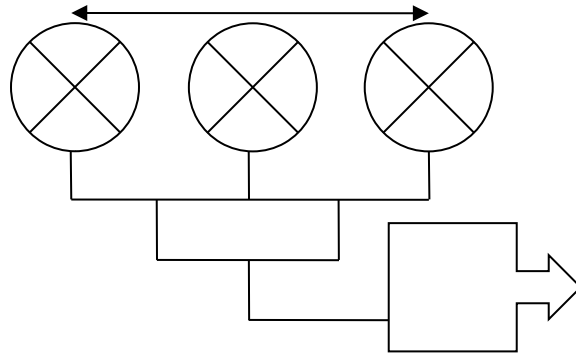

Multiple Drain Outlets

Incorrect

LESS THAN 3 FEET APART

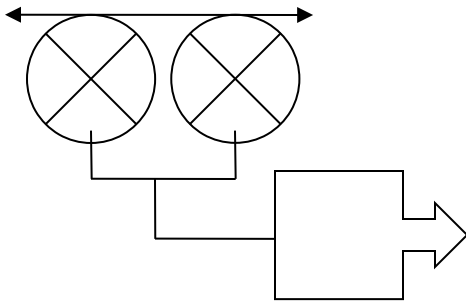

Incorrect

LESS THAN 3 FEET APART FROM OUTMOST OUTLET

