

# Porcine Deltacoronavirus (PDCoV) Case-farm Survey

## Section 1—Identification

1. Date of the interview (mm/dd/yy).....v101 \_\_\_\_\_ date
2. Name of data collector .....v102 \_\_\_\_\_ name
3. Name of herd veterinarian.....v103 \_\_\_\_\_ vet
4. Owner's name.....v104 \_\_\_\_\_ owner
5. Farm ID number (6 digits first two digits is state FIPS code).....v105 \_\_\_\_\_

## Section 2—System Information

The objective here is to draw a flow chart on a separate sheet of paper that describes the flow of pigs through the system that this site is a part of. Inventory, flow of pigs-including replacements and PDCoV status at each sister site- should be indicated. See **page 13** for an example.

## Section 3—Site Map

The objective here is to draw a map of the site on a separate sheet of paper in as much detail as you can (with the interviewee). Include the location of: rooms that broke first with PDCoV, arrows indicating room spread of PDCoV, different production areas (e.g., "Room 5-6-Nursery Isolation"), entry areas (showers, changing rooms, fogging rooms if applicable), entrance and exit doors, feed storage areas, parking, composting or dead area, manure storage and loading and unloading areas for pigs. See **page 14** for an example.

This rest of this form should be completed through a personal interview with the individual who has the greatest degree of knowledge of the information asked in each section (e.g., owner or herdsman). Ask each question as it is written and answer all questions. If a question is not applicable, **write or check NA**. If a respondent does not know the answer, **write or check DK** and try to get the answer at a future date. **A separate form should be completed for each site.**

## Section 4—Site Information

1. Which of the following best describes this site? (*Check one only.*) v401  
 <sub>1</sub> Wean to feeder  <sub>5</sub> Farrow to feeder  
 <sub>2</sub> Feeder to finish  <sub>6</sub> Breeding only (sows, gilts, preweaned pigs)  
 <sub>3</sub> Wean to finish  <sub>7</sub> Other (specify: \_\_\_\_\_)v401oth  
 <sub>4</sub> Farrow to finish
2. What was the inventory on this site the **day before** clinical signs of PDCoV began? If no animals of a particular type, **enter ZERO**.
  - a. Breeding pigs herd including on site replacement gilts.....v402 \_\_\_\_\_ number
  - b. Suckling pigs ..... v403 \_\_\_\_\_ number
  - c. Weaned market pigs.....v404 \_\_\_\_\_ number
  - d. Other pigs (specify: \_\_\_\_\_)v405oth.....v405 \_\_\_\_\_ number

According to the Paperwork Reduction Act of 1995, an agency may not conduct or sponsor, and a person is not required to respond to a collection of information unless it displays a valid OMB control number. The valid OMB control number for this information collection is 0579-0376. The time required to complete this information collection is estimated to average 2 hours per response, including the time to review instructions, search existing data resources, gather the data needed, and complete and review the information collected.

**NAHMS-341  
NOV 2014**

3. Do you currently have Porcine Reproductive & Respiratory Syndrome (PRRS) on this site?.....v406 <sub>1</sub> Yes <sub>3</sub> No
4. In general, How would you characterize the amount of bird droppings on the ground and structures on this site?.....v407 <sub>1</sub> Little <sub>2</sub> Moderate <sub>3</sub> Large
5. Please describe the facilities for each **pig building where pigs became ill on this site** (write in column heading ONCE, e.g., “gestation” and “farrowing” - if more than two types of facilities fill out this item in a separate form or on a separate piece of paper).

		Pig Type 1		Pig Type 2
a. What type of ventilation system (enter code from below) is used for the (column heading) housing facilities on this site? v408/v418		code		code
1 - Mechanical ventilation only 2 - Natural ventilation only	3 - Both natural and mechanical ventilation 4 - Other (specify: Type 1 _____ v408oth Type 2 _____)v418oth			
b. Is an air filtration system used in the (column heading) housing facilities on this site? v409/v419		Pig Type 1 <input type="checkbox"/> <sub>1</sub> Yes <input type="checkbox"/> <sub>3</sub> No		Pig Type 2 <input type="checkbox"/> <sub>1</sub> Yes <input type="checkbox"/> <sub>3</sub> No
1. If Yes above, was the air filtration (Check one only.): v410/v420	Full filtration <input type="checkbox"/> Seasonal filtration <input type="checkbox"/>			Full filtration <input type="checkbox"/> Seasonal filtration <input type="checkbox"/>
c. What type of manure handling system (enter code from below) is used for the (column heading) housing facilities on this site? v411/v421		code		code
1 - Shallow manure pit flushed with fresh water 2 - Shallow manure pit flushed with recycled water 3 - Shallow manure pit pull plug	4 - Deep manure pit pull plug 5 - Other (specify: Type 1 _____ v411oth Type 2 _____)v421oth			
d. Are these (column heading) housing facilities for the constructed and structurally maintained to keep out birds? v412/v422		Pig Type 1 <input type="checkbox"/> <sub>1</sub> Yes <input type="checkbox"/> <sub>3</sub> No		Pig Type 2 <input type="checkbox"/> <sub>1</sub> Yes <input type="checkbox"/> <sub>3</sub> No
<b>If No employees on the site, SKIP to 5f.</b>				
e. Before entering the (column heading) housing facilities on this site, are entrants required to:		Pig Type 1		Pig Type 2
1. Take a shower first. v413/v423		<input type="checkbox"/> <sub>1</sub> Yes <input type="checkbox"/> <sub>3</sub> No		<input type="checkbox"/> <sub>1</sub> Yes <input type="checkbox"/> <sub>3</sub> No
2. Change to clean boots and coveralls first. v414/v424		<input type="checkbox"/> <sub>1</sub> Yes <input type="checkbox"/> <sub>3</sub> No		<input type="checkbox"/> <sub>1</sub> Yes <input type="checkbox"/> <sub>3</sub> No
3. Use the Danish Entry or “Bench” system. v415/v425		<input type="checkbox"/> <sub>1</sub> Yes <input type="checkbox"/> <sub>3</sub> No		<input type="checkbox"/> <sub>1</sub> Yes <input type="checkbox"/> <sub>3</sub> No
4. Wait 24 hours or more after visiting any other hog site. v416/v426		<input type="checkbox"/> <sub>1</sub> Yes <input type="checkbox"/> <sub>3</sub> No		<input type="checkbox"/> <sub>1</sub> Yes <input type="checkbox"/> <sub>3</sub> No
f. Is a decontamination room used for receiving and processing supplies for this (column heading) housing facility (e.g., a fogging room)? v417/v427		Pig Type 1 <input type="checkbox"/> <sub>1</sub> Yes <input type="checkbox"/> <sub>3</sub> No		Pig Type 2 <input type="checkbox"/> <sub>1</sub> Yes <input type="checkbox"/> <sub>3</sub> No

**Section 5—PDCoV Site Outbreak Information**

1. When did clinical signs of PDCoV **first** appear in **any** pigs on this site?.....v501 \_\_\_\_\_ date
2. Please describe the disease for each **pig type** that **became ill on this site** (write in column heading ONCE, e.g., “Gestating sows,” or “lactating sows” and “preweaned piglets” - if more than two types of pigs fill out this item in a separate form or on a separate piece of paper).

	<b>Pig Type 1</b>		<b>Pig Type 2</b>
a. When did clinical signs of PDCoV <b>first</b> appear in (column heading) pigs on this site ( <b>one must match the date in Item 1</b> )? v502/v518	_____		_____
	date		date
b. Which of the following <b>clinical signs</b> of PDCoV were observed in (column heading) pigs on this site?	<b>Pig Type 1</b>		<b>Pig Type 2</b>
1. Watery diarrhea (no blood or mucus) v503/v519	<input type="checkbox"/> <sub>1</sub> Yes <input type="checkbox"/> <sub>3</sub> No		<input type="checkbox"/> <sub>1</sub> Yes <input type="checkbox"/> <sub>3</sub> No
2. Vomiting v504/v520	<input type="checkbox"/> <sub>1</sub> Yes <input type="checkbox"/> <sub>3</sub> No		<input type="checkbox"/> <sub>1</sub> Yes <input type="checkbox"/> <sub>3</sub> No
3. Anorexia v505/v521	<input type="checkbox"/> <sub>1</sub> Yes <input type="checkbox"/> <sub>3</sub> No		<input type="checkbox"/> <sub>1</sub> Yes <input type="checkbox"/> <sub>3</sub> No
4. Depression v506/v522	<input type="checkbox"/> <sub>1</sub> Yes <input type="checkbox"/> <sub>3</sub> No		<input type="checkbox"/> <sub>1</sub> Yes <input type="checkbox"/> <sub>3</sub> No
5. Fever v507/v523	<input type="checkbox"/> <sub>1</sub> Yes <input type="checkbox"/> <sub>3</sub> No		<input type="checkbox"/> <sub>1</sub> Yes <input type="checkbox"/> <sub>3</sub> No
<b>If no Type of animals got sick or died below in a week (or overall) enter ZERO</b>			
c. In the <b>first week</b> of PDCoV please provide the information below for each type of (column heading) pigs on this site.	<b>Pig Type 1</b>		<b>Pig Type 2</b>
1. Number animals with clinical signs v508/v524			
2. Number animals that died v509/v525			
d. In the <b>second week</b> of PDCoV please provide the information below for each type of (column heading) pigs on this site.	<b>Pig Type 1</b>		<b>Pig Type 2</b>
1. Number animals with clinical signs v510/v526			
2. Number animals that died v511/v527			
e. In the <b>third week</b> of PDCoV please provide the information below for each type of (column heading) pigs on this site.	<b>Pig Type 1</b>		<b>Pig Type 2</b>
1. Number animals with clinical signs v512/v528			
2. Number animals that died v513/v529			
f. In the <b>fourth week</b> of PDCoV please provide the information below for each type of (column heading) pigs on this site.	<b>Pig Type 1</b>		<b>Pig Type 2</b>
1. Number animals with clinical signs v514/v530			
2. Number animals that died v515/v531			
g. Was this PDCoV <b>fed back</b> to (column heading) pigs on this site?	<b>Pig Type 1</b>		<b>Pig Type 2</b>
1. If Yes, what date was feedback started? v516/v532	_____		_____
	date		date

3. Has this site been laboratory confirmed with PDCoV infection?.....v533 <sub>1</sub> Yes <sub>3</sub> No

**[If question 3 = No, SKIP to section 6.]**

4. To which veterinary diagnostic laboratory were the specimens submitted?
- a. Ohio State University.....v534 <sub>1</sub> Yes <sub>3</sub> No
- b. University of Minnesota.....v535 <sub>1</sub> Yes <sub>3</sub> No
- c. Iowa State University.....v536 <sub>1</sub> Yes <sub>3</sub> No
- d. Another veterinary diagnostic laboratory (specify: \_\_\_\_\_) v537oth/v537 <sub>1</sub> Yes <sub>3</sub> No
5. What date were the **first** specimens submitted?.....v538 \_\_\_\_\_ date

**Section 6—Porcine Epidemic Diarrhea (PED) Site Outbreak Information**

---

1. Has this site ever been laboratory confirmed with PED infection?.....v601 <sub>1</sub> Yes <sub>3</sub> No

**[If question 1 = No, SKIP to item 10.]**

2. When did clinical signs of PED **first** appear in **any** pigs on this site?.....v602 \_\_\_\_\_ date

3. To which veterinary diagnostic laboratory were the specimens submitted?

a. Ohio State University.....v603 <sub>1</sub> Yes <sub>3</sub> No

b. University of Minnesota.....v604 <sub>1</sub> Yes <sub>3</sub> No

c. Iowa State University.....v605 <sub>1</sub> Yes <sub>3</sub> No

d. Another veterinary diagnostic laboratory (specify: \_\_\_\_\_) v606oth/v606 <sub>1</sub> Yes <sub>3</sub> No

4. What date were the **first** specimens submitted?.....v607 \_\_\_\_\_ date

5. Were any changes made to visitor biosecurity protocols for this site following confirmation of PEDV?.....v608 <sub>1</sub> Yes <sub>3</sub> No <sub>4</sub> DK

a. **If Yes**, what **specific** changes were made? \_\_\_\_\_

\_\_\_\_\_v608a

6. Were any changes made to biosecurity protocols of personnel entering the hog and pig facilities on this site following confirmation of PEDV?.....v609 <sub>1</sub> Yes <sub>3</sub> No <sub>4</sub> DK

a. **If Yes**, what **specific** changes were made? \_\_\_\_\_

\_\_\_\_\_v609a

7. Were any changes made to biosecurity protocols for trucks, equipment or drivers for this site following confirmation of PEDV? .....v610 <sub>1</sub> Yes <sub>3</sub> No <sub>4</sub> DK

a. **If Yes**, what **specific** changes were made? \_\_\_\_\_

\_\_\_\_\_v610a

8. Were any changes made to feed processing for this site following confirmation of PEDV? .....v611 <sub>1</sub> Yes <sub>3</sub> No <sub>4</sub> DK

a. **If Yes**, what **specific** changes were made? \_\_\_\_\_

\_\_\_\_\_v611a

9. Were any changes made to feed ingredients used in rations on this site following confirmation of PEDV?.....v612 <sub>1</sub> Yes <sub>3</sub> No <sub>4</sub> DK

a. **If Yes**, what **specific** changes were made? \_\_\_\_\_

\_\_\_\_\_v612a

---

10. Were any changes made to visitor biosecurity protocols for this site based on **general concern** over PEDV?.....v613 <sub>1</sub> Yes <sub>3</sub> No <sub>4</sub> DK

**If Yes**, what **specific** changes were made? \_\_\_\_\_

\_\_\_\_\_v613a

11. Were any changes made to biosecurity protocols of personnel entering the hog and pig facilities on this site based on **general concern** over PEDV?.....v614 <sub>1</sub> Yes <sub>3</sub> No <sub>4</sub> DK  
 a. **If Yes**, what **specific** changes were made? \_\_\_\_\_  
 \_\_\_\_\_  
 \_\_\_\_\_v614a
12. Were any changes made to biosecurity protocols for trucks, equipment or drivers for this site based on **general concern** over PEDV?.....v615 <sub>1</sub> Yes <sub>3</sub> No <sub>4</sub> DK  
 a. **If Yes**, what **specific** changes were made? \_\_\_\_\_  
 \_\_\_\_\_  
 \_\_\_\_\_v615a
13. Were any changes made to feed processing for this site based on **general concern** over PEDV?.....v616 <sub>1</sub> Yes <sub>3</sub> No <sub>4</sub> DK  
 a. **If Yes**, what **specific** changes were made? \_\_\_\_\_  
 \_\_\_\_\_  
 \_\_\_\_\_v616a
14. Were any changes made to feed ingredients used in rations on this site based on **general concern** over PEDV?.....v617 <sub>1</sub> Yes <sub>3</sub> No <sub>4</sub> DK  
 a. **If Yes**, what **specific** changes were made? \_\_\_\_\_  
 \_\_\_\_\_  
 \_\_\_\_\_v617a

The rest of this questionnaire will frequently ask about the “**10 days before the date of onset of PDCoV.**” This refers to the date given in **Section 5, item 1**. Write the beginning and end dates of the 10 days before here for reference. \_\_\_\_\_

### Section 7—Visitors

1. During the **10 days before the date of onset** of PDCoV (**Section 5, Item 1**), did anyone from a foreign country visit this site?.....v701 <sub>1</sub> Yes <sub>3</sub> No <sub>4</sub> DK
2. During the **10 days before the date of onset** of PDCoV, did anyone from this site who works with pigs, including your veterinarian or their partners, return from a foreign country? (*Include employees who may no longer be on this operation.*).....v702 <sub>1</sub> Yes <sub>3</sub> No <sub>4</sub> DK  
 a. **If Yes**, what countries were visited, and when? \_\_\_\_\_v702a

**For the next two questions, consider all visitors to this site, such as service people (mechanical, electrical), veterinarians, contractors, salespeople, neighbors, other pig producers, consultants, exterminators, etc.**

3. In the **10 days before the date of onset** of PDCoV, did any **nonemployees** enter the hog and pig facilities on this site? .....v703 <sub>1</sub> Yes <sub>3</sub> No
4. In the **10 days before the date of onset** of PDCoV, were there any **nonemployees** who visited this site but **did not** enter the hog and pig facilities? .....v704 <sub>1</sub> Yes <sub>3</sub> No
5. Were there any unusual occurrences, or security breaches, on this site during the **10 days before the date of onset** of PDCoV? (e.g., locked doors found unlocked, unknown cars or people seen on the premises, etc.).....v705 <sub>1</sub> Yes <sub>3</sub> No <sub>4</sub> DK  
 a. **If Yes**, please describe, including the date of the occurrence:  
 \_\_\_\_\_  
 \_\_\_\_\_v705a



- b. The animal area **inside** of the truck be **disinfected**?.....v810 <sub>1</sub> Yes <sub>3</sub> No  
 1. **If Yes**, please specify with what product: \_\_\_\_\_v810a
- c. The outside of the truck be cleaned?.....v811 <sub>1</sub> Yes <sub>3</sub> No  
 1. **If Yes**, please specify with what (e.g., clean water, recycled water, etc.):  
 \_\_\_\_\_v811a
- d. The outside of the truck be disinfected?.....v812 <sub>1</sub> Yes <sub>3</sub> No  
 1. **If Yes**, please specify with what product: \_\_\_\_\_v812a
- e. Other cleaning and disinfecting protocols are performed.....v813 <sub>1</sub> Yes <sub>3</sub> No  
 1. **If Yes**, please specify: \_\_\_\_\_v813a

4. Is the animal area **inside** the truck required to be inspected prior to entering the site? ..... v814 <sub>1</sub> Yes <sub>3</sub> No
5. Is the **truck cab** required to be inspected prior to entering the site?.....v815 <sub>1</sub> Yes <sub>3</sub> No
6. Is the truck wash used (N/A means that trucks are not washed)
- a. Dedicated to this site/system?.....v816 <sub>1</sub> Yes <sub>3</sub> No <sub>2</sub> N/A
- b. Community/public truck wash?.....v817 <sub>1</sub> Yes <sub>3</sub> No <sub>2</sub> N/A
7. In the **10 days before the date of onset** of PDCoV (**Section 5, Item 1**), did anything change (e.g., new drivers) related to trucking companies or truck transport on this site?.....v818 <sub>1</sub> Yes <sub>3</sub> No  
 a. **If Yes**, please describe: \_\_\_\_\_v818a
8. For any trucks that visited this site in the **10 days before the date of onset** of PDCoV, did they visit a confirmed PDCoV positive site within 72 hours prior to visiting this site?.....v819 <sub>1</sub> Yes <sub>3</sub> No <sub>4</sub> DK
9. In the **10 days before the date of onset** of PDCoV, did this site borrow any:
- a. Equipment or machinery from another swine site?.....v820 <sub>1</sub> Yes <sub>3</sub> No
- b. Vehicles from another swine site?.....v821 <sub>1</sub> Yes <sub>3</sub> No
- c. Trailers from another swine site?.....v822 <sub>1</sub> Yes <sub>3</sub> No

1. **If Yes**, please list **dates** and **describe**:

\_\_\_\_\_  
 \_\_\_\_\_v822a

**Section 9—Pigs Added to Herd**

1. During the **10 days before the date of onset** of PDCoV (**Section 5, Item 1**), were any pigs added to this site?.....v901 <sub>1</sub> Yes <sub>3</sub> No

**If NO pigs added to this site during the 10 days before the date of onset of PDCoV, SKIP to Section 10.**

a. **If Yes**, list dates and pig sources during the **10 days before PDCoV** (if more space is needed use a separate piece of paper):

Date	Source of pigs (enter code from List 1 below)	Type of pigs added (enter code from List 2 below)	# Head added
p902	p911	p920	p929
p903	p912	p921	p930
p904	p913	p922	p931
p905	p914	p923	p932
p906	p915	p924	p933
p907	p916	p925	p934
p908	p917	p926	p935
p909	p918	p927	p936
p910	p919	p928	p937
<b>List 1</b>		<b>List 2</b>	
1. Another site belonging to this operation 2. Other pig producer(s) (eg, farm-to-farm, contract or non-contract) 3. An auction, sale barn, or livestock market 4. Another source (specify _____)v901oth		1. Nursery piglets less than 60 lbs. 2. Feeder pigs, or pigs in weight range 60 to 249 pounds 3. Market hogs, or hogs ≥ 250 pounds 4. Breeding animal (intended for use in breeding, whether permanent or temporary move)	

2. Were any pigs introduced on this site **10 days before the date of onset** of PDCoV sourced from a site that has been confirmed positive for PDCoV?.....v938 <sub>1</sub> Yes <sub>3</sub> No <sub>4</sub> DK
3. In the **10 days before the date of onset** of PDCoV, did anything change related to pigs sources for this site?.....v939 <sub>1</sub> Yes <sub>3</sub> No
- a. **If Yes**, please describe: \_\_\_\_\_v940

**If Item 1 included breeding animals coming on to this site ask Items 4-7 about Breeding animals that are Replacement gilts**

4. At what age (in days-approximate) do replacement gilts come onto the site?.....v941 \_\_\_\_\_ days
5. Are replacement gilts from a known negative PDCoV source?.....v942 <sub>1</sub> Yes <sub>3</sub> No
6. Are replacement gilts isolated?.....v943 <sub>1</sub> Yes <sub>3</sub> No
- a. **If Yes**, How long (in days) are replacement gilts isolated?.....v944 \_\_\_\_\_ days
7. Do you sample replacement gilts for PDCoV?.....v945 <sub>1</sub> Yes <sub>3</sub> No

## Section 10—Feed Sources

1. Please describe the feed consumed by each **pig type from Section 5, Item 2** that **became ill on this site** (write in column heading ONCE, e.g., “Gestating sows” or “lactating sows”, “nursery,” “finisher,” and “preweaned Piglets” - if more than two types of pigs or more than two types of rations fill out this item in a separate form or on a separate piece of paper).

a. Which code below best describes how the feed for the (column heading) phase on this site was <b>purchased and delivered</b> in the <b>10 days before the date of onset</b> of PDCoV? v1001/v1004	<b>Pig Type 1</b> <hr style="width: 80%; margin: 0 auto;"/> code	<b>Pig Type 2</b> <hr style="width: 80%; margin: 0 auto;"/> code	
1 - Complete feed 2 - Mixed by the site 3 - Mixed by the farm/company but off site	4 - Custom-mixed off site (not by the site’s company) 5 - Other (specify: Type 1 _____ v1001oth Type 2 _____)v1004oth		
b. Were all feed ingredients in this ration <b>above</b> for the (column heading) phase sourced within the United States? v1002/v1005	<b>Pig Type 1</b> <input type="checkbox"/> <sub>1</sub> Yes <input type="checkbox"/> <sub>3</sub> No <input type="checkbox"/> <sub>4</sub> DK	<b>Pig Type 2</b> <input type="checkbox"/> <sub>1</sub> Yes <input type="checkbox"/> <sub>3</sub> No <input type="checkbox"/> <sub>4</sub> DK	
c. What code below best describes the as-fed form of the ration <b>above</b> for the (column heading) phase? v1003/v1006	<b>Pig Type 1</b> <hr style="width: 80%; margin: 0 auto;"/> code	<b>Pig Type 2</b> <hr style="width: 80%; margin: 0 auto;"/> code	
1 - Meal 2 - Mash 3 – Pellet 4 - Liquid	5 - Other (specify: Type 1 _____ v1003oth Type 2 _____)v1006oth		
d. Please list that dates that each type of feed for the (column heading) that was <b>purchased and delivered</b> on the site in the <b>10 days before the onset</b> of PDCoV ( <b>Section 5, Item 1</b> ) and the name of the feed mill or site (off site) for the (column heading) or corporate source of the feed component ( <b>if mixed on site</b> ).			
<b>Pig Type 1</b>		<b>Pig Type 2</b>	
<b>Dates</b>	<b>Feed mill/source</b>	<b>Dates</b>	<b>Feed mill/source</b>
v1008	v1015	v1022	v1029
v1009	v1016	v1023	v1030
v1010	v1017	v1024	v1031
v1011	v1018	v1025	v1032
v1012	v1019	v1026	v1033
v1013	v1020	v1027	v1034
v1014	v1021	v1028	v1035

2. Please describe the components of the feed being consumed on this site in the **10 days before the onset of PDCoV (Section 5, Item 1)** for each type of pig on this site (if more than two types of pigs or more than two types of feed per pig fill out this item in a separate form or on a separate piece of paper).

<b>Pig Type 1 feed (Pig type _____)</b>			
<b>Component</b>	<b>Component in this feed?</b>	<b>If Yes, Company Name of this component (e.g., "Sowcorn 300")</b>	<b>Source of this component (e.g., company name)</b>
Tallow (animal fat from cattle or sheep)	<input type="checkbox"/> <sub>1</sub> Yes <input type="checkbox"/> <sub>3</sub> No v1036	v1056	v1078
Lard or choice white grease (pork fat)	<input type="checkbox"/> <sub>1</sub> Yes <input type="checkbox"/> <sub>3</sub> No v1037	v1057	v1079
Other <b>animal fat</b> (specify: _____) v1038oth	<input type="checkbox"/> <sub>1</sub> Yes <input type="checkbox"/> <sub>3</sub> No v1038	v1058	v1080
Soybean oil	<input type="checkbox"/> <sub>1</sub> Yes <input type="checkbox"/> <sub>3</sub> No v1039	v1059	v1081
Corn oil	<input type="checkbox"/> <sub>1</sub> Yes <input type="checkbox"/> <sub>3</sub> No v1040	v1060	v1082
Other <b>vegetable fat</b> (specify: _____) v1041oth	<input type="checkbox"/> <sub>1</sub> Yes <input type="checkbox"/> <sub>3</sub> No v1041	v1061	v1083
Molasses	<input type="checkbox"/> <sub>1</sub> Yes <input type="checkbox"/> <sub>3</sub> No v1042	v1062	v1084
Spray dried plasma	<input type="checkbox"/> <sub>1</sub> Yes <input type="checkbox"/> <sub>3</sub> No v1043	v1063	v1085
Blood meal, serum albumin, or other blood products	<input type="checkbox"/> <sub>1</sub> Yes <input type="checkbox"/> <sub>3</sub> No v1044	v1064	v1086
Mucosal products such as dried porcine soluble	<input type="checkbox"/> <sub>1</sub> Yes <input type="checkbox"/> <sub>3</sub> No v1045	v1065	v1087
Fish meal	<input type="checkbox"/> <sub>1</sub> Yes <input type="checkbox"/> <sub>3</sub> No v1046	v1066	v1088
Feather meal	<input type="checkbox"/> <sub>1</sub> Yes <input type="checkbox"/> <sub>3</sub> No v1047	v1067	v1089
Meat meal or meat-and-bone meal	<input type="checkbox"/> <sub>1</sub> Yes <input type="checkbox"/> <sub>3</sub> No v1048	v1068	v1090
Soybean meal or other vegetable protein source	<input type="checkbox"/> <sub>1</sub> Yes <input type="checkbox"/> <sub>3</sub> No v1049	v1069	v1091
Other <b>protein</b> sources (specify: _____) v1050oth	<input type="checkbox"/> <sub>1</sub> Yes <input type="checkbox"/> <sub>3</sub> No v1050	v1070	v1092
Bakery/food manufacture byproducts (not table waste)	<input type="checkbox"/> <sub>1</sub> Yes <input type="checkbox"/> <sub>3</sub> No v1051	v1071	v1093
Distiller's dried grain and solubles (DDGS)	<input type="checkbox"/> <sub>1</sub> Yes <input type="checkbox"/> <sub>3</sub> No v1052	v1072	v1094
Vitamins	<input type="checkbox"/> <sub>1</sub> Yes <input type="checkbox"/> <sub>3</sub> No v1053	v1073	v1095
Minerals	<input type="checkbox"/> <sub>1</sub> Yes <input type="checkbox"/> <sub>3</sub> No v1054	v1074	v1096
Other component (specify: _____) v1055oth	<input type="checkbox"/> <sub>1</sub> Yes <input type="checkbox"/> <sub>3</sub> No v1055	v1075	v1097
Other component (specify: _____) v1056oth	<input type="checkbox"/> <sub>1</sub> Yes <input type="checkbox"/> <sub>3</sub> No v1056	v1076	v1098
Other component (specify: _____) v1057oth	<input type="checkbox"/> <sub>1</sub> Yes <input type="checkbox"/> <sub>3</sub> No v1057	v1077	v1099

**Pig Type 2 feed (Pig type \_\_\_\_\_)**

Component	Component in this feed?	If Yes, Company Name of this component (e.g., "Sowcorn 300")	Source of this component (e.g., company name)
Tallow (animal fat from cattle or sheep)	<input type="checkbox"/> <sub>1</sub> Yes <input type="checkbox"/> <sub>3</sub> No v1100	v1122	v1144
Lard or choice white grease (pork fat)	<input type="checkbox"/> <sub>1</sub> Yes <input type="checkbox"/> <sub>3</sub> No v1101	v1123	v1145
Other <b>animal fat</b> (specify: _____) v1102oth	<input type="checkbox"/> <sub>1</sub> Yes <input type="checkbox"/> <sub>3</sub> No v1102	v1124	v1146
Soybean oil	<input type="checkbox"/> <sub>1</sub> Yes <input type="checkbox"/> <sub>3</sub> No v1103	v1125	v1147
Corn oil	<input type="checkbox"/> <sub>1</sub> Yes <input type="checkbox"/> <sub>3</sub> No v1104	v1126	v1148
Other <b>vegetable fat</b> (specify: _____) v1105oth	<input type="checkbox"/> <sub>1</sub> Yes <input type="checkbox"/> <sub>3</sub> No v1105	v1127	v1149
Molasses	<input type="checkbox"/> <sub>1</sub> Yes <input type="checkbox"/> <sub>3</sub> No v1106	v1128	v1150
Spray dried plasma	<input type="checkbox"/> <sub>1</sub> Yes <input type="checkbox"/> <sub>3</sub> No v1107	v1129	v1151
Blood meal, serum albumin, or other blood products	<input type="checkbox"/> <sub>1</sub> Yes <input type="checkbox"/> <sub>3</sub> No v1108	v1130	v1152
Mucosal products such as dried porcine soluble	<input type="checkbox"/> <sub>1</sub> Yes <input type="checkbox"/> <sub>3</sub> No v1109	v1131	v1153
Fish meal	<input type="checkbox"/> <sub>1</sub> Yes <input type="checkbox"/> <sub>3</sub> No v1110	v1132	v1154
Feather meal	<input type="checkbox"/> <sub>1</sub> Yes <input type="checkbox"/> <sub>3</sub> No v1111	v1133	v1155
Meat meal or meat-and-bone meal	<input type="checkbox"/> <sub>1</sub> Yes <input type="checkbox"/> <sub>3</sub> No v1112	v1134	v1156
Soybean meal or other vegetable protein source	<input type="checkbox"/> <sub>1</sub> Yes <input type="checkbox"/> <sub>3</sub> No v1113	v1135	v1157
Other <b>protein</b> sources (specify: _____) v1114oth	<input type="checkbox"/> <sub>1</sub> Yes <input type="checkbox"/> <sub>3</sub> No v1114	v1136	v1158
Bakery/food manufacture byproducts (not table waste)	<input type="checkbox"/> <sub>1</sub> Yes <input type="checkbox"/> <sub>3</sub> No v1115	v1137	v1159
Distiller's dried grain and solubles (DDGS)	<input type="checkbox"/> <sub>1</sub> Yes <input type="checkbox"/> <sub>3</sub> No v1116	v1138	v1160
Vitamins	<input type="checkbox"/> <sub>1</sub> Yes <input type="checkbox"/> <sub>3</sub> No v1117	v1139	v1161
Minerals	<input type="checkbox"/> <sub>1</sub> Yes <input type="checkbox"/> <sub>3</sub> No v1118	v1140	v1162
Other component (specify: _____) v1119oth	<input type="checkbox"/> <sub>1</sub> Yes <input type="checkbox"/> <sub>3</sub> No v1119	v1141	v1163
Other component (specify: _____) v1120oth	<input type="checkbox"/> <sub>1</sub> Yes <input type="checkbox"/> <sub>3</sub> No v1120	v1142	v1164
Other component (specify: _____) v1121oth	<input type="checkbox"/> <sub>1</sub> Yes <input type="checkbox"/> <sub>3</sub> No v1121	v1143	v1165

3. In the **10 days before the date of onset** of PDCoV, did anything change related to pig feed sources or ingredients for this site?..... v1166 <sub>1</sub> Yes <sub>3</sub> No

a. **If Yes**, please describe:

\_\_\_\_\_ v1166a

## Section 11—Conclusion

---

1. Think of all the people and things that come and go to keep this site running. For example, visitors, trucks, trailers, feed, pigs, equipment, and semen. Can you think of anything that changed, such as suppliers, truckers, vaccine protocols, employees, etc., **during the 10 days before the onset** of PDCoV clinical signs?..... v1167 <sub>1</sub> Yes <sub>3</sub> No

a. **If Yes**, please describe below, including the date of the change: (If none, Enter "None" in box.)

2. What is your theory about how this site became infected with PDCoV? (If none, Enter "None" in box.)

3. How was this survey conducted? (*Check one only.*) v1168  
<sub>1</sub> In person  
<sub>2</sub> By telephone  
<sub>3</sub> By mail or email

4. Who answered the questions? (*Check one only.*) v1169  
<sub>1</sub> Herd manager  
<sub>2</sub> Veterinarian  
<sub>3</sub> Other (specify \_\_\_\_\_)v1169oth

5. Can the veterinary diagnostic laboratory be contacted to obtain results or information about virus isolates?.....v1170 <sub>1</sub> Yes <sub>3</sub> No

6. If necessary, can feed or other input samples be collected from this site?.....v1171 <sub>1</sub> Yes <sub>3</sub> No

**Comments** (Please add any comments regarding this site or site that you believe may be of interest to this survey below.)

## Section 12—System Information Example

---

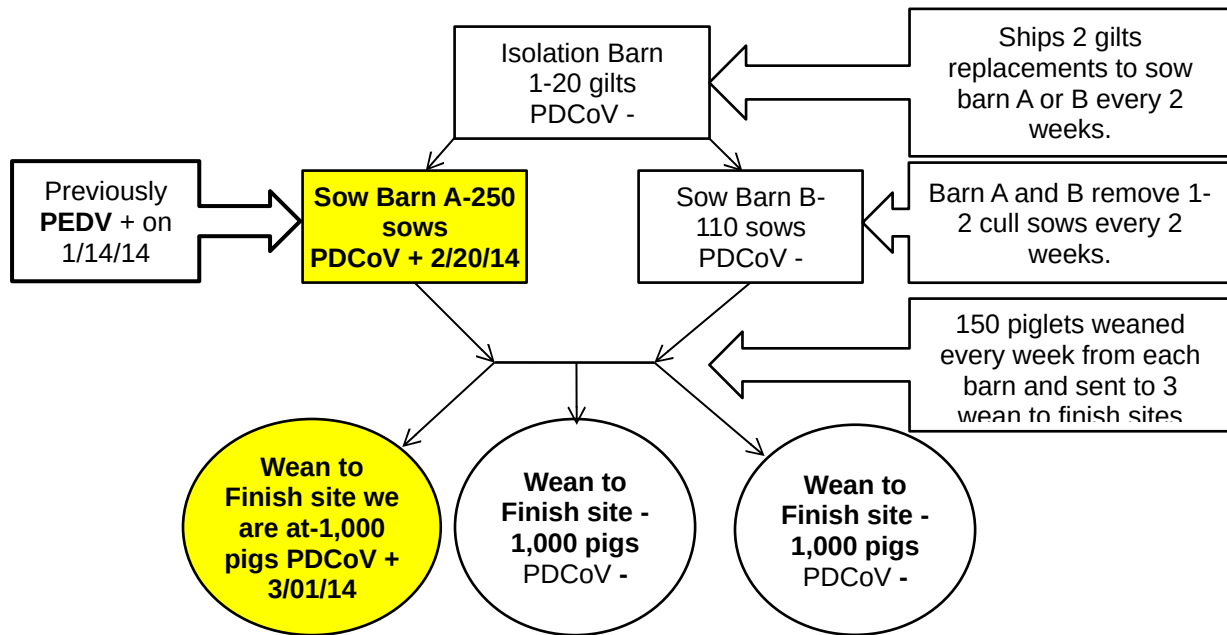

## Section 13—Site Map Example

